

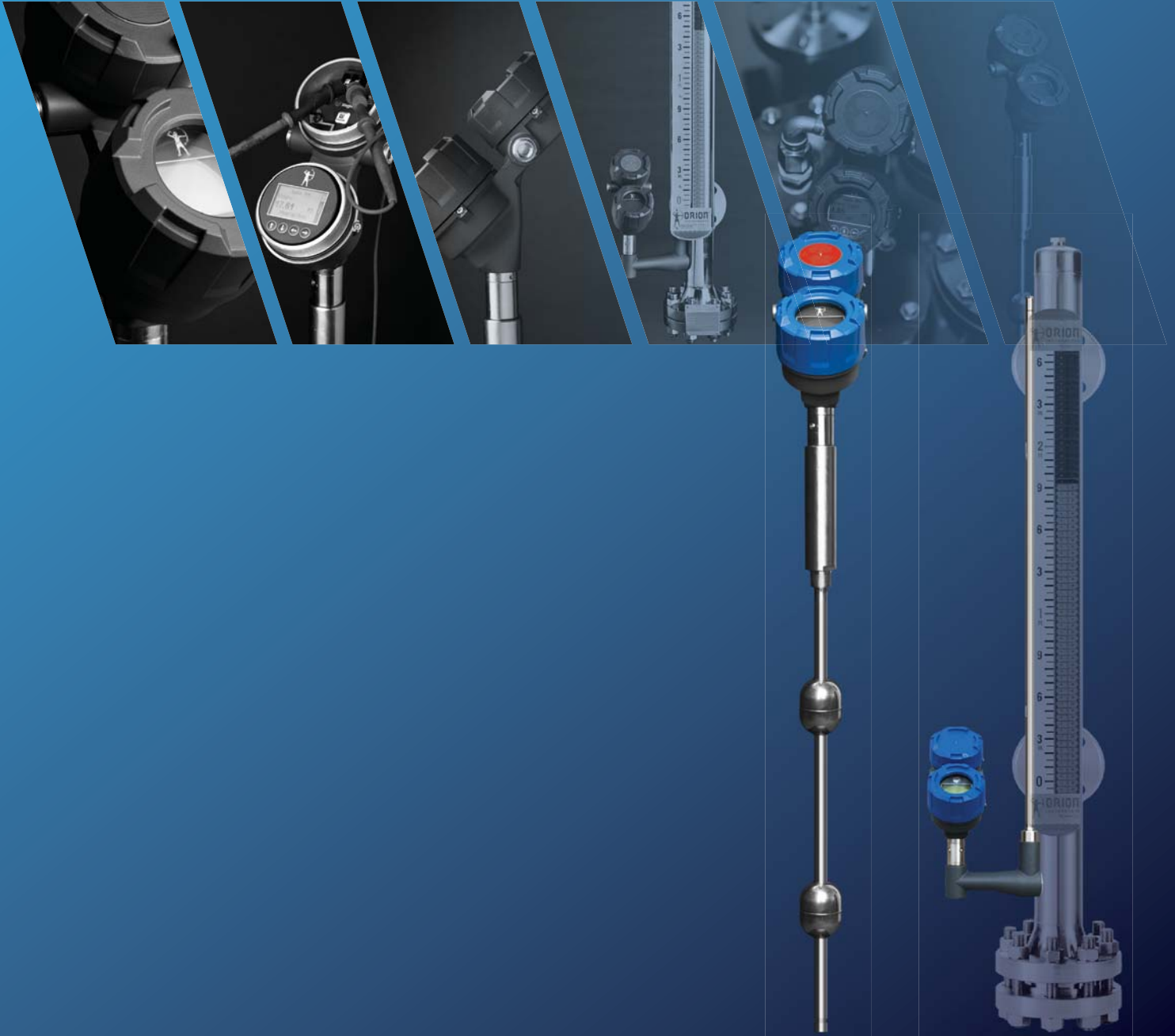

ORION[®]
INSTRUMENTS
A  Magnetrol[®] Company

JUPITER[®] Model JM4 MAGNETOSTRICTIVE LEVEL TRANSMITTER



Magnetrol[®]

Worldwide Level and Flow SolutionsSM

TECHNOLOGY

LOW-VOLTAGE PULSE ①

On-board electronics send a low-voltage electrical pulse down the magnetostrictive wire at the speed of light, ten times per second.

MAGNETS ②

Magnets contained within the float focus their energy toward the wire at the precise location of the liquid level.

TWIST ③

Interaction between the magnetic field, electrical pulse, and magnetostrictive wire cause a slight mechanical disturbance in the wire that travels back up the probe at the speed of sound.

PIEZOELECTRIC CRYSTALS ④

The mechanical wave is converted back into electrical energy by two piezoelectric crystals. The on-board electronics interpret the time-of-flight data and indicate the position of the float magnets.

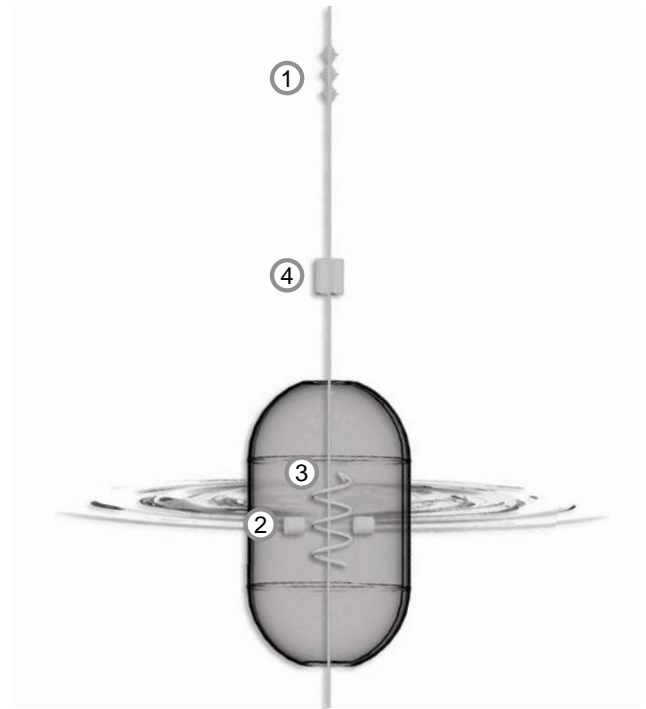

APPLICATIONS

As direct insertion model: Jupiter can be mounted inside a bridle, stillwell, external cage or directly inside the vessel.

As external mount model: Jupiter can be mounted on the outside of a magnetic level indicator (MLI).

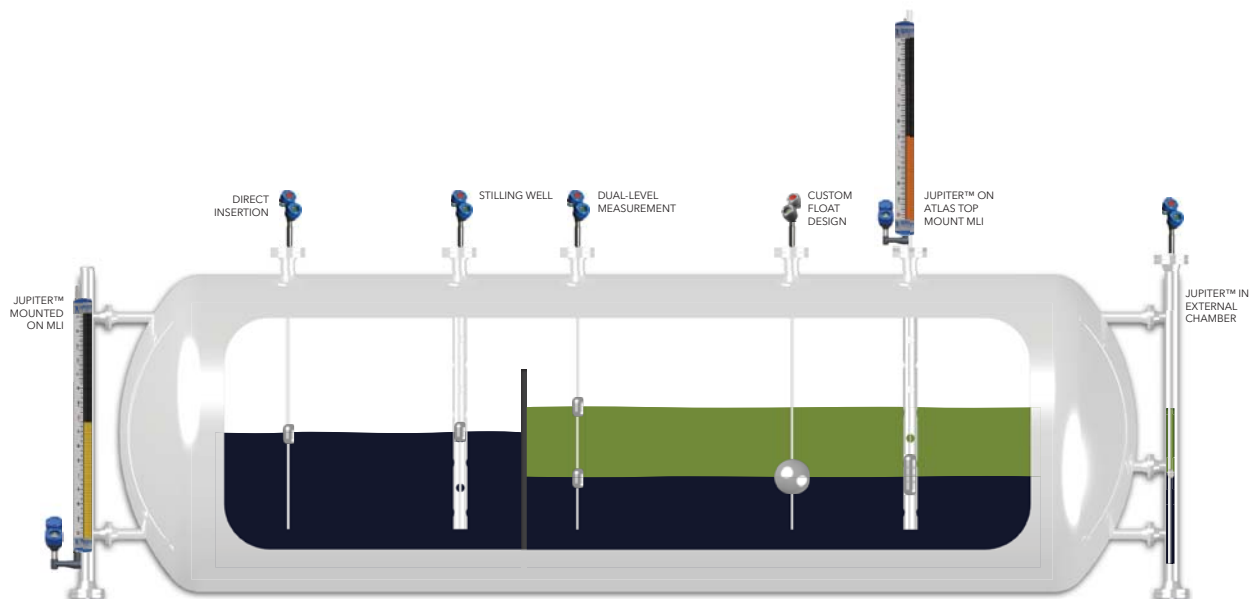

FEATURES

SAFER

Jupiter possesses a comprehensive array of advanced diagnostics and real-time performance monitoring which make gathering transmitter insight faster and easier than ever before. With profound focus on SIS (Safety Instrumented Systems), Jupiter was developed with SSA (Safety Suitable Architecture), as well as memory protection hardware & software.

In addition, such features as non-volatile event history information, hot swappable control modules, configurable alarm delays and context sensitive help screens and parameters makes this one of the easiest transmitters on the market to work with.



REMOVABLE & ROTATABLE TRANSMITTER HEAD

A first among magnetostrictive devices, Jupiter revolutionizes installation options and flexibility with a transmitter head which can rotate up to 310 degrees, drastically improving LCD visibility and access to the user interface in hard-to-reach places. In addition, a removable head minimizes installation challenges, permits interchangeability without breaching the process seal, and allows for remote transmitter placement.



SMARTER

Orion introduces auto-configuration to magnetostrictive technology with Jupiter's new Smart Probe. When the transmitter head connects to a probe for the first time, configuration settings stored within the probe's memory are instantly transferred. In addition, parameters critical to the instrument's calibration are transferred as well, eliminating the need for Jupiter to be manually calibrated in the field. This unique capability expedites the setup process and simplifies the task of installing spare transmitter heads on existing or replacement probes.



SIMPLE, FEATURE-RICH USER INTERFACE

Jupiter takes the user experience to new levels of convenience and functionality with an information-rich display and an easy-to-navigate menu. With the new graphic LCD, waveforms are viewable locally at the device. You can also interface with Jupiter via a capable DCS or handheld communicator that utilize DDs/EDDL for remote connectivity.

A fully redesigned and upgraded DTM puts real-time and historical trend data at your fingertips. With a basic laptop, a HART modem, and the free-to-download program PACTware™, the transmitter can be accessed locally or from anywhere in the loop. You can also capture live waveforms, which are invaluable when configuring the transmitter for optimal performance.

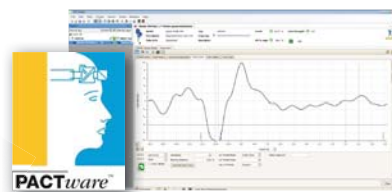

OPTIONS

REMOTE MOUNTED ELECTRONICS

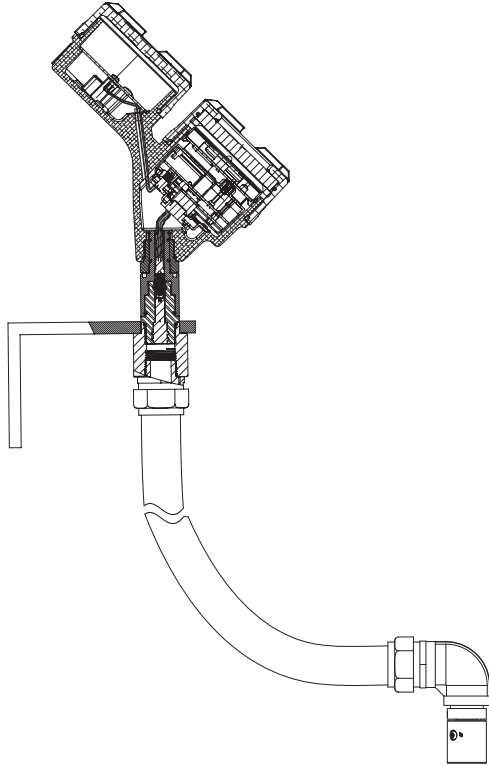

Remote mount option, ideal for installation space constraints.

VIBRATION KIT

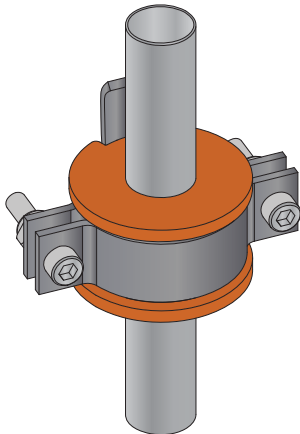

Silicone-based damping material eliminates metal-on-metal contact between the probe and the chamber. Increases signal stability in high vibration applications by reducing mechanical noise.

SUNSHADE

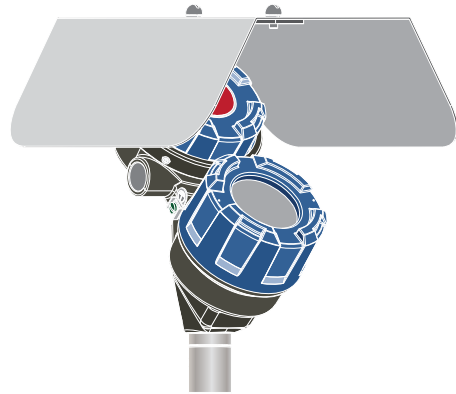

Reduces glare and radiant heating of the transmitter enclosure. Also minimizes impact of direct solar radiation to the graphic liquid crystal display.

CENTERING DISC



The centering disc is an invaluable aid when utilizing the Jupiter in a direct insertion environment, such as a stilling well or modular instrumentation bridge. By keeping the transmitter probe centered, potential for impingement is mitigated.

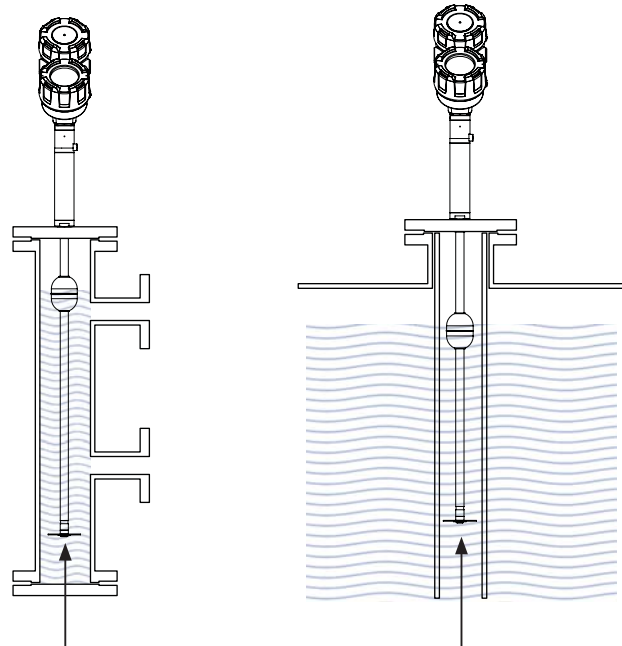

Units mounted in stilling wells or chambers are provided with centering disc at the base of the probe, guaranteeing free movement of the float.

SPECIFICATIONS

System Design	
Measurement Principle	Magnetostriction-based mechanical response signal
Input	
Measured Variable	Level, response signal time of flight
Span	15 cm to 999 cm (6" to 400")
Output	
Type	4 to 20 mA with HART: 3.8 mA to 20.5 mA usable (per NAMUR NE43) Foundation fieldbus™: H1 (ITK Ver. 6.1.1)
Resolution	Analog: 0.003 mA Digital Display: 1 mm
Loop Resistance	591 ohms @ 24 V DC and 22 mA
Diagnostic Alarm	Selectable: 3.6 mA, 22 mA (meets requirements of NAMUR NE 43), or HOLD last output
Damping	Adjustable 0-10 seconds
User Interface	
Keypad	4-button menu-driven data entry
Display	Graphic liquid crystal display with viewable echo curve
Digital Communication	HART Version 7—with Field Communicator, Foundation fieldbus™, DTM (PACTware™), AMS, FDT, EDDL
Menu Languages	Transmitter LCD: English, French, German, Spanish, Russian, Portuguese HART DD: English, French, German, Spanish, Russian, Chinese, Portuguese Foundation fieldbus™ Host System: English
Power (at transmitter terminals)	HART: General Purpose (Weather proof)/Intrinsically Safe/Explosion-proof: 16 to 36 V DC 11 V DC minimum under certain conditions FOUNDATION fieldbus™: FISCO 9 to 17.5 V DC FISCO, FNICO, Explosion Proof, General Purpose (Weather Proof): 9 to 32 V DC
Housing	
Material	IP67/cast aluminum A413 (<0.6% copper); optional 316 stainless steel
Net/Gross Weight	Aluminum: 2,0 kg (4.5 lbs.) Stainless Steel: 4,50 kg (10.0 lbs.)
Overall Dimensions	Transmitter Head: H 212 mm (8.34") x W 102 mm (4.03") x D 192 mm (7.56")
Cable Entry	1/2" NPT-F or M20 x 1,5
SIL 2 Hardware (Safety Integrity Level)	Safe Failure Fraction = 93.1 % for Single Float version, 91.9 % for Dual Float version (HART only) Functional Safety to SIL 2 as 1oo1 in accordance with IEC 61508 (Full FMEDA report available upon request)
Performance	
Linearity	0,8 mm (0.030") or 0.01 % of probe length, whichever is greater
Accuracy	±0.01 % full scale or ± 1,3 mm (0.05"), whichever is greater
Resolution	0,4 mm (0.014")
Repeatability	±0.005 % of full span or 0,4 mm (0.014"), whichever is greater
Response Time	1 second
Initialization Time	Less than 10 seconds
Ambient Temperature Effect	Approx. ±0.02 % of probe length/°C
Execution Time	15 msec (30 msec PID, Signal Characterizer Block)

SPECIFICATIONS

Foundation fieldbus™

ITK Version	6.1.1
H1 Device Class	Link Master (LAS)—selectable ON/OFF
H1 Profile Class	31PS, 32L
Function Blocks	(6) AI, (2) Transducer, (1) Resource, (1) Arithmetic, (1) Input Selector, (1) Signal Characterizer, (2) PID, (1) Integrator
Quiescent Current	15 mA
Execution Time	15 msec (30 msec PID, Signal Characterizer Block)

Environment

Ambient Temperature Range	Transmitter: -40 °C to +80 °C (-40 °F to +176 °F) Display: -20 °C to +80 °C (-5 °F to +176 °F)
Storage Temperature	-45 °C to +85 °C (-50 °F to +185 °F)
Process Pressure (Direct Insertion)	Vacuum to 3000 psi (207 bar)
Humidity	0 to 99 %, non-condensing
Electromagnetic Compatibility	Meets CE requirement (EN 61326) and NAMUR NE 21
Surge Protection	Meets CE EN 61326 (1000 V)
Shock/Vibration	ANSI/ISA-S71.03 Class SA1 (Shock); ANSI/ISA-S71.03 Class VC2 (Vibration)



PROCESS CONDITIONS

Process Temperature	External Mount: -196 °C (-320 °F) to +450 °C (+850 °F) Direct Insertion: -196 °C (-320 °F) to +425 °C (+800 °F)
Process Pressure	Direct Insertion: Vacuum to 207 bar (3000 psi)

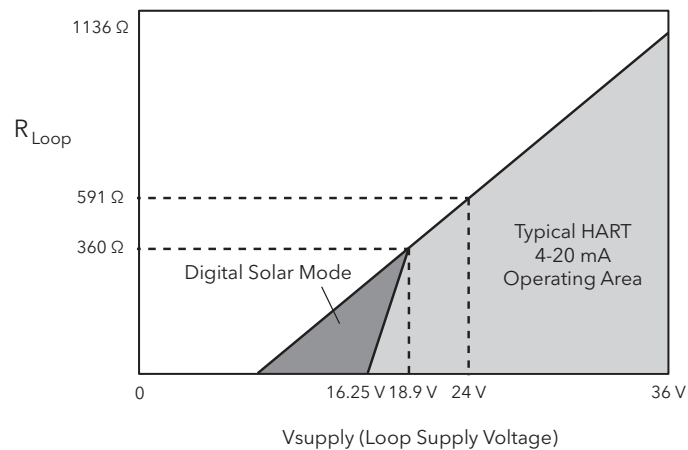
Safe Operating Area



APPROVALS

Agency	Protection Method	Area Classification
	Explosion Proof	Class I, Div 1, Group B, C and D, T4 Ta = -40 °C to +70 °C Type 4X, IP67
	Intrinsically Safe	Class I, II, III, Div 1, Group A, B, C, D, E, F, G, T4 Class I, Zone 0 AEx ia IIC T4 Ga Class I, Zone 0 Ex ia IIC T4 Ga Ta = -40 °C to +70 °C Type 4X, IP67
	Non-Incendive	U.S.: Class I, II, III, Division 2, Group A, B, C, D, E, F, G, T4, Ta = -40 °C to 70 °C CANADA: Class I, Division 2, Group A,B,C,D T4, Ta = -40 °C to 70 °C Class I, Zone 2 AEx nA IIC T4 Gc Ta = -15 °C to 70 °C Class I, Zone 2 Ex nA IIC T4 Gc Ta = -15 °C to +70 °C Type 4X, IP67
	Dust Ignition Proof	Class II, III, Division 1, Group E, F and G, T4 Ta = -40 °C to +70 °C Type 4X, IP67
	Flame Proof	<i>Pending -- inquire for availability</i>
	Intrinsically Safe	II 1 G Ex ia IIC T4 Ga Ta = -40 °C to +70 °C IP67
	Non Sparking	II 3 G Ex nA IIC T4 Gc Ta = -15 °C to +70 °C IP67
	Dust Ignition Proof	II 2 D Ex tb IIIC T85 °C ... T120 °C Db Ta = -15 °C to +70 °C IP67
	Flame Proof	<i>Pending -- inquire for availability</i>
	Intrinsically Safe	Ex ia IIC T4 Ga Ta = -40 °C to +70 °C IP67
	Non Sparking	Ex nA IIC T4 Gc Ta = -15 °C to +70 °C IP67
	Dust Ignition Proof	Ex tb IIIC T85 °C ... T120 °C Db Ta = -15 °C to +70 °C IP67



These units are in compliance with the EMC directive 2014/30/EU, the PED directive 2014/68/EU and the ATEX directive 2014/34/EU.

THE FOLLOWING APPROVAL STANDARDS ARE APPLICABLE:

FM3600:2011, FM3610:2010, FM3611:2004, FM3615:2006, FM3616:2011, FM3810:2005, ANSI/ISA60079-0:2013, ANSI/ISA 60079-1:2009, ANSI/ISA 60079-11:2013, ANSI/ISA 60079-15:2012, ANSI/ISA 60079-26:2011, NEMA 250:2003, ANSI/IEC 60529:2004, C22.2 No. 0.4:2009, C22.2 No. 0.5:2008, C22.2 No. 30:2007, C22.2 No. 94:2001, C22.2 No. 157:2012, C22.2 No. 213:2012, C22.2 No. 1010.1:2009, CAN/CSA 60079-0:2011, CAN/CSA 60079-1:2011, CAN/CSA 60079-11:2011, CAN/CSA 60079-15:2012, C22.2 No. 60529:2005, EN60079-0:2012, EN60079-11:2012, EN60079-15:2010, EN60079-31:2009, EN60529+A1:1991-2000, IEC60079-0:2011, IEC60079-11:2011, IEC60079-15:2010, IEC60079-31:2008

SPECIAL CONDITIONS FOR SAFE USE:

1. The enclosure contains aluminum and is considered to present a potential risk of ignition by impact or friction. Care must be taken during installation and use to prevent impact or friction. **2.** To maintain the T4 temperature code care shall be taken to ensure the enclosure temperature does not exceed 70 °C. **3.** The risk of electrostatic discharge shall be minimized at installation, following the direction given in the instruction. **4.** For installation with ambient temperature of 70 °C, refer to the manufacturer's instructions for guidance on proper selection of conductors. **5.** Provisions shall be made to provide transient overvoltage protection to a level not to exceed 119 V DC. **6.** WARNING - Explosion Hazard do not disconnect equipment when flammable or combustible atmosphere is present **7.** When equipment is used in explosive dust atmospheres, the end user shall take precautions so that the thermal effects of the process temperature shall limit the equipment enclosure and probe surface temperatures to not exceed the required installation location temperature and shall be between T85 °C and T120 °C.

NOTES:

1. For Explosion proof installations the I.S. ground terminal shall be connected to appropriate intrinsically safe ground in accordance with the Canadian Electrical code (CEC) or the national electrical code (NEC). For intrinsically safe installations the I.S. ground terminal does not require grounding. **2.** Manufacturer's installation instructions supplied with the protective barrier and the CEC or the NEC must be followed when installing this equipment. Barrier must be certified for Canadian & U.S. installation. **3.** Control equipment connected to protective barriers must not use or generate more than 250 V DC or VRMS. **4.** Agency approved dust tight seals must be used when transmitter is installed in Class II & III environments. **5.** For supply connections, use wire suitable for the operating temperature. **6.** Agency approved barriers with linear output characteristics must be used.

SELECTION DATA

A complete measuring system consists of:

1. Jupiter JM4 transmitter head/electronics.
2. Jupiter JM4 probe (direct insertion or external mount).
3. Option: ATLAS magnetic level indicator for use with external mount model JM4. Consult bulletin BE 46-138.
4. Free of charge: Jupiter JM4 DTM (PACTware™) can be downloaded from www.magnetrol.com.
5. Option: MACTek Viator USB HART® interface: order code: **070-3004-002**.

1. Order code for Jupiter JM4 transmitter head/electronics

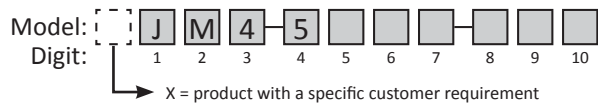

1-3 | BASIC MODEL NUMBER

JM4	Jupiter JM4 magnetostrictive level transmitter
-----	--

4 | POWER

5	24 V DC, two wire loop powered
---	--------------------------------

5-6 | OUTPUT / ELECTRONICS

11	4-20 mA with HART® - SIL enhanced electronics (full FMEDA report available)
20	Foundation Fieldbus™ communication

7 | ACCESSORIES/MOUNTING

0	No digital display and keypad - Integral
1	No digital display and keypad - Remote 91 cm (36") ①
2	No digital display and keypad - Remote 3,66 m (144") ①
A	Digital display and keypad - Integral
B	Digital display and keypad - Remote 91 cm (36") ①
C	Digital display and keypad - Remote 3,66 m (144") ①

① Only available in combination with digit 8 = 0, 1, A, C.

8 | CLASSIFICATION

0	Weatherproof (IP 67)
1	cFMus intrinsically safe (digit 5 = 1); cFMus FISCO field device (digit 5 = 2)
3	cFMus explosion proof (digit 5 = 1); cFMus explosion proof & FNICO field device (digit 5 = 2)
A	ATEX / IEC intrinsically safe
B	ATEX / IEC flameproof enclosure (pending)
C	ATEX / IEC non sparking
D	ATEX / IEC dust Ex

9 | HOUSING

1	Cast aluminium
2	Cast 316 stainless steel

10 | CABLE ENTRY / SUNSHADE OPTION

0	1/2" NPT-F (2 entries - 1 plugged)- No sunshade
1	M20 x 1,5 (2 entries - 1 plugged) - No sunshade
2	1/2" NPT-F (2 entries - 1 plugged)- Aluminium sunshade
3	M20 x 1,5 (2 entries - 1 plugged) - Aluminium sunshade

2. Order code for Jupiter JM4 external mount probe

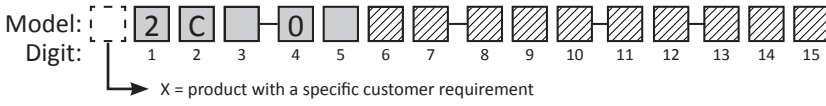

1-3 | BASIC MODEL NUMBER

2CE	Standard	top mount	-40 °C (-40 °F) ≤ T ≤ 260 °C (500 °F)
2CF	Standard	top mount offset	
2CH	Standard	bottom mount offset	
2CK	High temperature	top mount	260 °C (500 °F) < T ≤ 450 °C (850 °F)
2CL	High temperature	top mount offset	
2CM	High temperature	bottom mount offset	
2CR	Cryogenic	top mount	-196 °C (-320 °F) ≤ T ≤ 65 °C (150 °F)
2CS	Cryogenic	top mount offset	
2CT	Cryogenic	bottom mount offset	

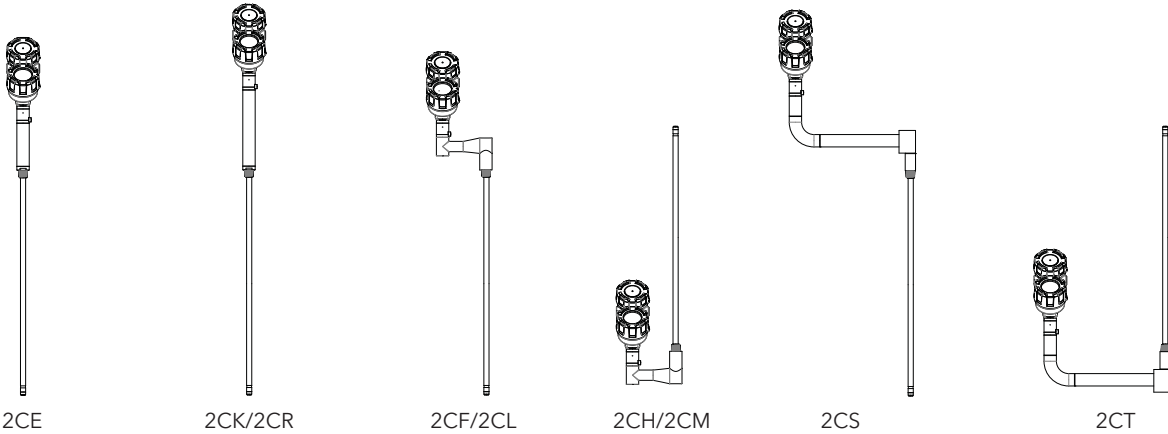

4-5 | MOUNTING LOCATION

00	Left side mount on MLI or chamber (standard)
01	Right side mount on MLI or chamber

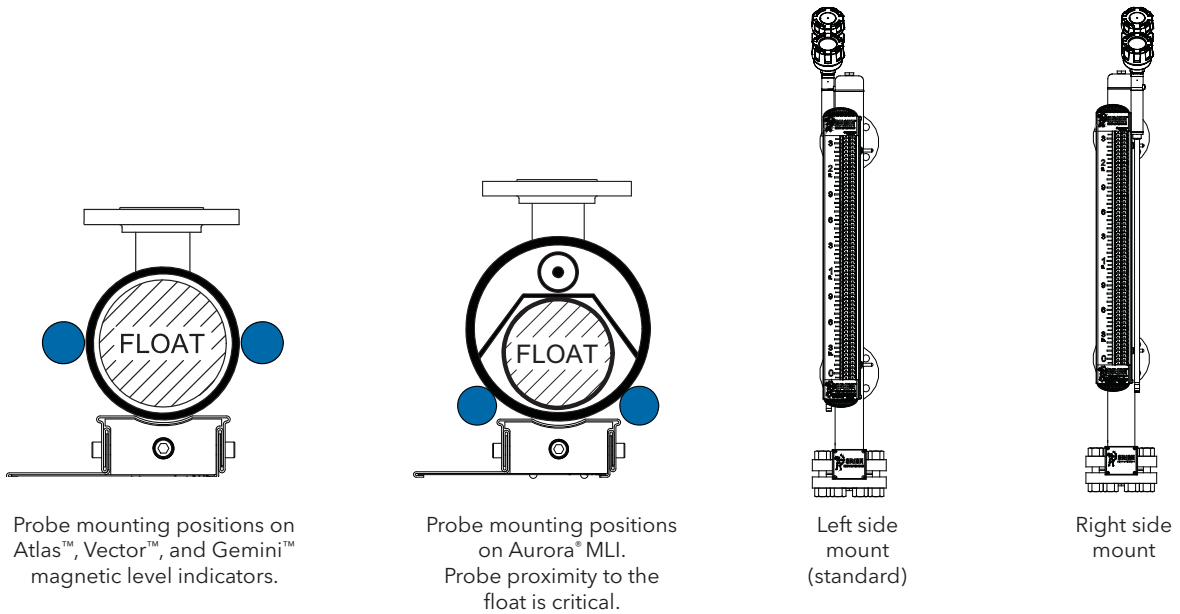

2. Order code for Jupiter JM4 external mount probe

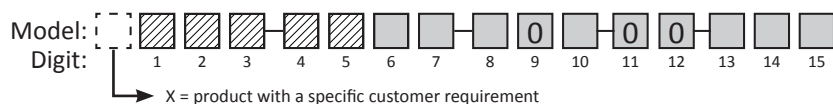

6 | MATERIALS OF CONSTRUCTION

Sensor enclosure: refer to shaded areas in sketches

A	316 stainless steel probe with powder-coated aluminium sensor enclosure ①
1	316 stainless steel probe with 316 stainless steel sensor enclosure

① Only available in combination with digit 3 = F, H, L, M.

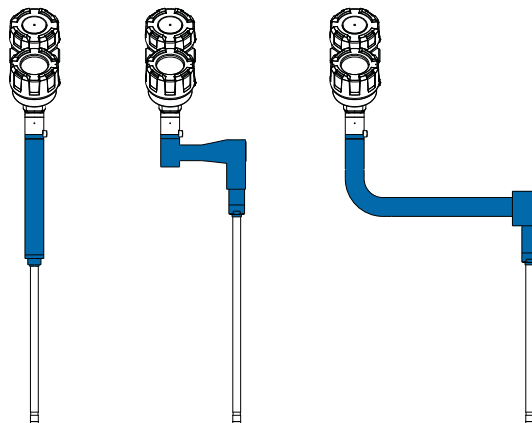

7 | PROBE OPTIONS

N	None
V	Vibration-resistant probe mounting

8 | CHAMBER MOUNTING HARDWARE CODE

Without high-temp chamber insulation

1	MLI with a 2" ANSI chamber
2	MLI with a 2 1/2" ANSI chamber
3	MLI with a 3" ANSI chamber
4	MLI with a 4" ANSI chamber
5	MLI is a top mount design
0	None (if clamps already exist)

With high-temp chamber insulation

E	MLI with a 2" ANSI chamber
F	MLI with a 2 1/2" ANSI chamber
G	MLI with a 3" ANSI chamber
H	MLI with a 4" ANSI chamber
J	MLI is a top mount design
0	None (if clamps already exist)

9 | NOT USED

0	None
---	------

10 | LEVEL / INTERFACE MEASUREMENT

1	Measure only the total liquid level
2	Measure only the interface level
3	Measure both total and interface level

11-12 | NOT USED

00	None
----	------

13-15 | PROBE LENGTH - Specify per cm (0.39") increment

Probe length calculation: - Top mount without offset: probe length = active span + 20 cm (8")

- Top / bottom mount with offset: probe length = active span + 15 cm (6")

030	Min 30 cm (12")
999	Max 999 cm (393")

2. Order code for Jupiter JM4 direct insertion probe

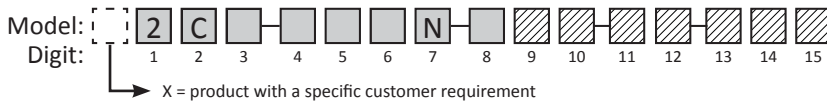

1-3 | BASIC MODEL NUMBER

2C1	Standard probe	$-40\text{ }^{\circ}\text{C} (-40\text{ }^{\circ}\text{F}) \leq T \leq 260\text{ }^{\circ}\text{C} (500\text{ }^{\circ}\text{F})$
2C2	High temperature probe	$260\text{ }^{\circ}\text{C} (500\text{ }^{\circ}\text{F}) < T \leq 425\text{ }^{\circ}\text{C} (800\text{ }^{\circ}\text{F})$
2C8	Cryogenic probe	$-196\text{ }^{\circ}\text{C} (-320\text{ }^{\circ}\text{F}) \leq T \leq 65\text{ }^{\circ}\text{C} (150\text{ }^{\circ}\text{F})$

4-5 | MOUNTING CONNECTION

Float to be mounted from the inside of the tank for small process connections.
 Refer to the sizing chart for chambers and stilling wells.

Threaded (male)

11	3/4" NPT
41	2" NPT

22	1" BSP (G 1")
42	2" BSP (G 2")

ANSI flanges

43	2"	150 lbs	ANSI RF
44	2"	300 lbs	ANSI RF
45	2"	600 lbs	ANSI RF
47	2"	900/1500 lbs	ANSI RF
53	3"	150 lbs	ANSI RF
54	3"	300 lbs	ANSI RF
55	3"	600 lbs	ANSI RF

56	3"	900 lbs	ANSI RF
57	3"	1500 lbs	ANSI RF
63	4"	150 lbs	ANSI RF
64	4"	300 lbs	ANSI RF
65	4"	600 lbs	ANSI RF
66	4"	900 lbs	ANSI RF
67	4"	1500 lbs	ANSI RF

EN (DIN) flanges

DA	DN 50	PN 16	EN 1092-1 Type A
DB	DN 50	PN 25/40	EN 1092-1 Type A
DD	DN 50	PN 63	EN 1092-1 Type B2
DE	DN 50	PN 100	EN 1092-1 Type B2
EA	DN 80	PN 16	EN 1092-1 Type A
EB	DN 80	PN 25/40	EN 1092-1 Type A
ED	DN 80	PN 63	EN 1092-1 Type B2

EE	DN 80	PN 100	EN 1092-1 Type B2
FA	DN 100	PN 16	EN 1092-1 Type A
FB	DN 100	PN 25/40	EN 1092-1 Type A
FD	DN 100	PN 63	EN 1092-1 Type B2
FE	DN 100	PN 100	EN 1092-1 Type B2
FF	DN 100	PN 160	EN 1092-1 Type B2
FG	DN 100	PN 250	EN 1092-1 Type B2

6 | MATERIAL OF CONSTRUCTION (wetted parts only)

A	316 stainless steel
B	Hastelloy® C
C	Monel®
L	316 stainless steel with Teflon®-S coating on probe tubing and float
P	316 stainless steel with PFA coating on probe tubing and float

7 | NOT USED

N	None
---	------

8 | INSTALLATION CONSIDERATIONS

N	Direct insertion unit mounted in vessel without stilling well
C	Direct insertion unit mounted in chamber, bridle or stilling well ①

① Refer to the sizing chart for chambers & stilling wells.

2. Order code for Jupiter JM4 direct insertion probe

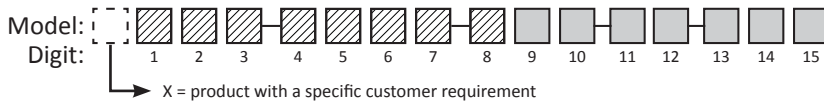

Sizing chart for chambers & stilling wells

Reference the chart below to identify an appropriate chamber or stilling well size for your application. Adequate clearance is recommended to ensure proper operation.

Float Diameter mm (inches)	Probe lengths ≤ 366 cm (144")						Probe lengths > 366 cm (144")	
	3" sch. 5/10	3" sch. 40	4" sch. 5/10	4" sch. 40	4" sch. 80	4" sch. 160	4" sch. 10	4" sch. 40
47 (1.85)	•	•	•	•	•	•	•	•
51 (2.0)	•		•	•	•	•	•	•
57 (2.25)			•	•	•		•	
64 (2.5)			•	•				
76 (3.0)								

9 | CONSTRUCTION GRADE

0	Industrial
K	ASME B31.1
L	ASME B31.3
M	ASME B31.3 & NACE MR0175/MR0103
N	Industrial & NACE MR0175/MR0103

10 | LEVEL / INTERFACE MEASUREMENT

1	Measure only the total liquid level
2	Measure only the interface level
3	Measure both total and interface level

11-12 | MAGNETIC FLOAT(S)

See separate page for our standard direct insertion floats offering. If a listed float does not meet your application requirements, consult factory for a custom design.

13-15 | PROBE LENGTH - Specify per cm (0.39") increment

030	Min 30 cm (12")
999	Max 999 cm (393")

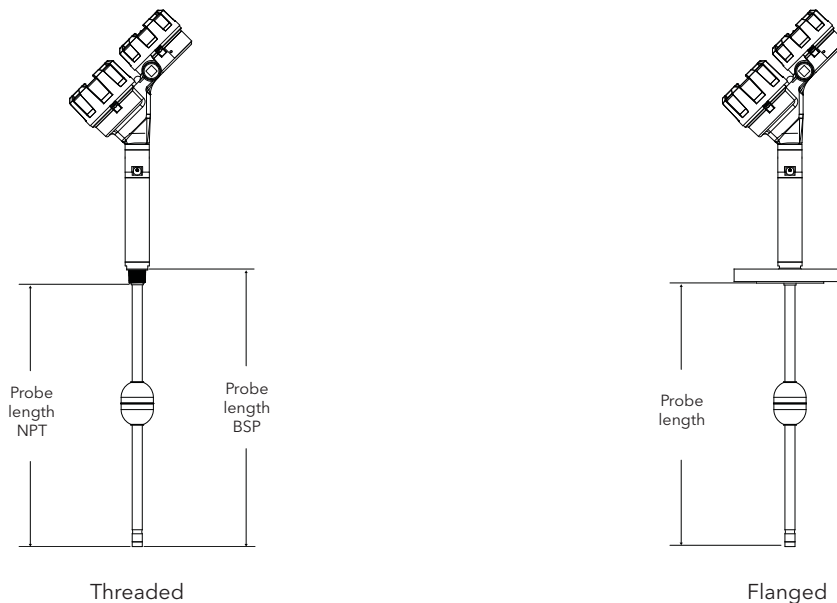

DIRECT INSERTION FLOATS

The floats listed below are suitable for most applications. Select the appropriate 2-digit float code and place it in the direct insertion probe model number (digits 11 & 12). Consult factory for custom floats or to consult about your specific application.

Direct insertion total level float (uppermost liquid layer)

Minimum liquid specific gravity	316/316L SST	Titanium	Hastelloy® C
≥ 0,86	AA Ø 51 mm (2.0")	BA Ø 51 mm (2.0")	CA Ø 47 mm (1.85")
≥ 0,83	AA Ø 51 mm (2.0")	BA Ø 51 mm (2.0")	CB Ø 57 mm (2.25")
≥ 0,7	AB Ø 58 mm (2.3")	BA Ø 51 mm (2.0")	CB Ø 57 mm (2.25")
≥ 0,68	AB Ø 58 mm (2.3")	BB Ø 57 mm (2.25")	99 consult factory
≥ 0,64	AC Ø 64 mm (2.5")	BB Ø 57 mm (2.25")	99 consult factory
≥ 0,52	99 consult factory	BB Ø 57 mm (2.25")	99 consult factory
< 0,52	99 consult factory	99 consult factory	99 consult factory

Direct insertion interface level float (lower or middle liquid layer) ①

Minimum liquid specific gravity upper / lower	316/316L SST	Titanium	Hastelloy® C
sinks through / floats on ≤ 0,89 / ≥ 1,00	MA Ø 51 mm (2.0")	NA Ø 51 mm (2.0")	PA Ø 47 mm (1.85")
sinks through / floats on ≤ 1,00 / ≥ 1,12	MB Ø 51 mm (2.0")	NB Ø 51 mm (2.0")	PB Ø 47 mm (1.85")

① Consult factory for other S.G. values.

PRESSURE/TEMPERATURE RATINGS FOR STANDARD FLOATS

Temp °C (°F)	Pressure rating (includes 1,5 x safety factor) bar (psi)				
	AA, AB, AC, MA, MB	BA, NA, NB	BB	CA, PA, PB	CB
20 (70)	30,3 (440)	51,7 (750)	27,6 (400)	23,4 (340)	22,1 (320)
40 (100)	30,3 (440)	48,9 (709)	26,1 (378)	23,4 (340)	22,1 (320)
95 (200)	30,3 (440)	38,5 (559)	20,5 (298)	23,4 (340)	22,1 (320)
120 (250)	30,3 (440)	34,1 (494)	18,1 (263)	23,4 (340)	22,1 (320)
150 (300)	30,3 (440)	30,1 (437)	16,1 (233)	23,4 (340)	22,1 (320)
175 (350)	30,2 (438)	26,6 (386)	14,2 (206)	23,4 (340)	22,1 (320)
200 (400)	29,4 (427)	23,5 (341)	12,5 (182)	23,4 (340)	22,1 (320)
230 (450)	28,3 (411)	20,9 (303)	11,2 (162)	23,2 (337)	21,9 (318)
260 (500)	27,3 (396)	18,8 (273)	10,1 (146)	23,1 (335)	21,7 (315)
290 (550)	26,5 (385)	17,2 (250)	9,2 (133)	22,5 (326)	21,1 (306)
315 (600)	25,8 (374)	16,0 (232)	8,5 (124)	21,8 (316)	20,5 (298)
345 (650)	25,3 (367)	15,0 (217)	8,0 (116)	21,2 (308)	19,9 (289)
370 (700)	24,9 (361)	14,1 (205)	7,5 (109)	20,6 (299)	19,4 (281)
400 (750)	24,5 (356)	13,2 (192)	7,0 (102)	20,4 (296)	19,2 (278)
425 (800)	24,3 (352)	12,2 (177)	6,5 (94)	20,2 (293)	19,0 (276)

PHYSICAL DIMENSIONS

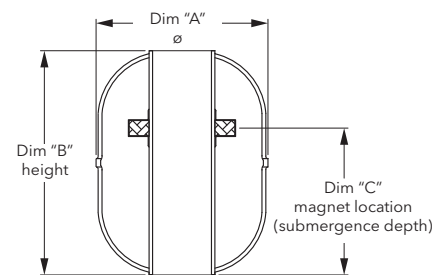

Float Code	Dim. A mm (inch)	Dim. B mm (inch)	Dim. C mm (inch)
AA	51 (2.0)	69 (2.7)	47 (1.84)
AB	58 (2.3)	76 (3.0)	51 (2.0)
AC	64 (2.5)	76 (3.0)	54 (2.14)
BA	51 (2.0)	71 (2.8)	50 (1.98)
BB	57 (2.25)	76 (3.0)	53 (2.08)
CA	47 (1.85)	76 (3.0)	52 (2.06)
CB	57 (2.25)	109 (4.3)	76 (3.01)
MA	51 (2.0)	69 (2.7)	34 (1.35)
MB	51 (2.0)	69 (2.7)	34 (1.35)
NA	51 (2.0)	71 (2.8)	36 (1.4)
NB	51 (2.0)	71 (2.8)	36 (1.4)
PA	47 (1.85)	76 (3.0)	38 (1.5)
PB	47 (1.85)	76 (3.0)	38 (1.5)

Two floats for total level and interface measurement

When utilizing two floats to measure total and interface liquid levels, reference the chart to determine the appropriate float code to insert into the Jupiter® model number.

Code	Total	Interface
11	AA	MA
12	AB	
13	AC	
21	AA	MB
22	AB	
23	AC	
31	BA	NA

Code	Total	Interface
32	BB	NA
41	BA	NB
42	BB	
51	CA	PA
52	CB	
61	CA	PB
62	CB	

DIMENSIONS in mm (inches)

Transmitter head/electronics

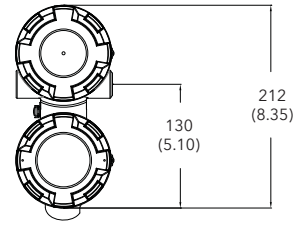
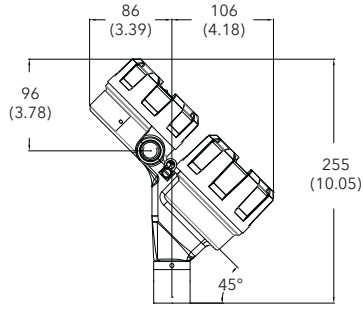
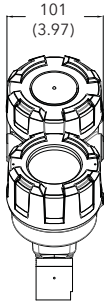

45° view

Units with external mount probe

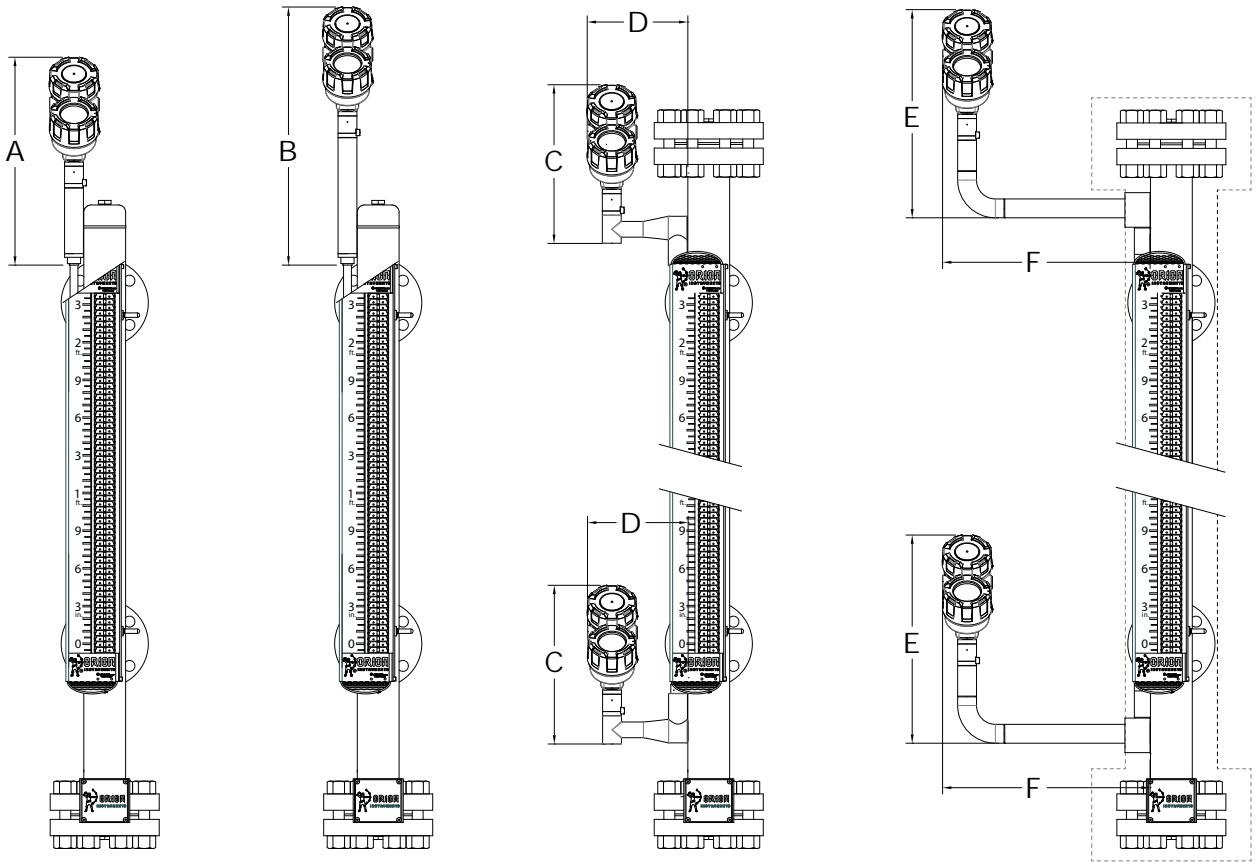

Dashed line represents cryogenic insulation.

Probe model	Dimensions	
2CE	A = 417 (16.4)	
2CK, 2CR	B = 518 (20.4)	
2CF, 2CH, 2CL, 2CM	C = 323 (12.7)	D = 203 (8.0)
2CS, 2CT	E = 422 (16.6)	F = 419 (16.5)

Units with direct insertion probe

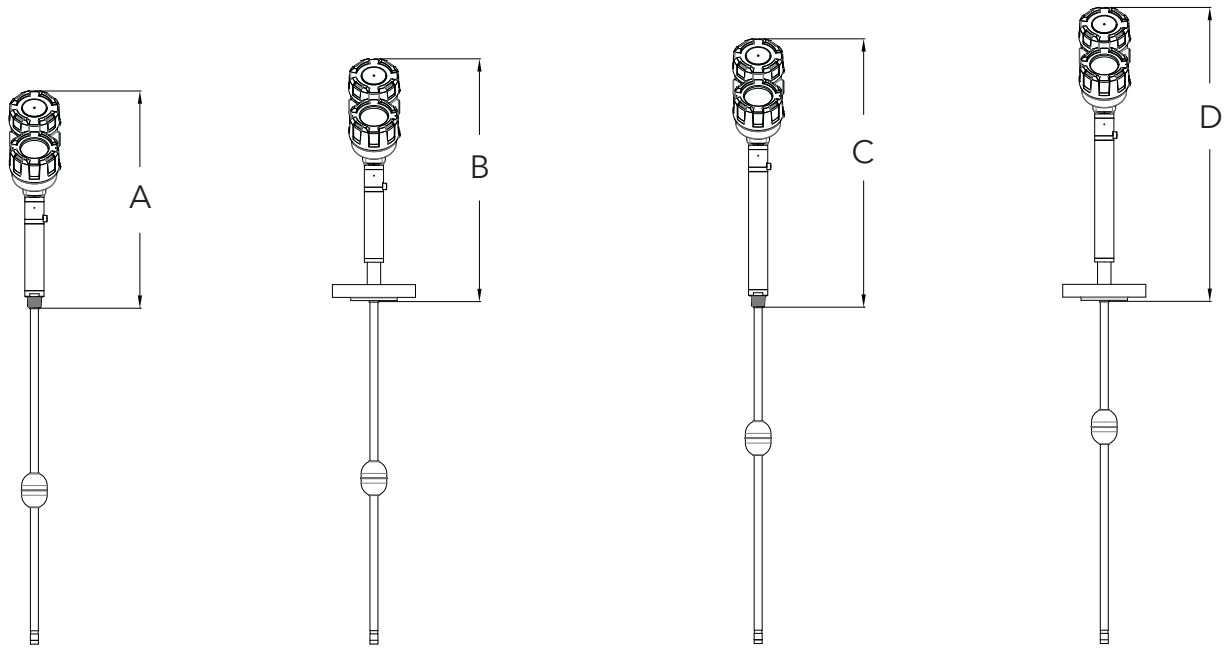

Probe model	Dimensions	
	Threaded	Flanged
2C1	A = 432 (17.0)	B = 483 (19.0)
2C2, 2C8	C = 533 (21.0)	D = 584 (23.0)



QUALITY ASSURANCE - ISO 9001:2008
THE QUALITY ASSURANCE SYSTEM IN PLACE AT MAGNETROL GUARANTEES THE HIGHEST LEVEL OF QUALITY DURING THE DESIGN, THE CONSTRUCTION AND THE SERVICE OF CONTROLS.
OUR QUALITY ASSURANCE SYSTEM IS APPROVED AND CERTIFIED TO ISO 9001:2008 AND OUR TOTAL COMPANY IS COMMITTED TO PROVIDING FULL CUSTOMER SATISFACTION BOTH IN QUALITY PRODUCTS AND QUALITY SERVICE.

PRODUCT WARRANTY

ALL JUPITER® LEVEL CONTROLS ARE WARRANTED FREE OF DEFECTS IN MATERIALS AND WORKMANSHIP FOR ONE FULL YEAR FROM THE DATE OF ORIGINAL FACTORY SHIPMENT.

IF RETURNED WITHIN THE WARRANTY PERIOD; AND, UPON FACTORY INSPECTION OF THE CONTROL, THE CAUSE OF THE CLAIM IS DETERMINED TO BE COVERED UNDER THE WARRANTY; THEN, MAGNETROL INTERNATIONAL WILL REPAIR OR REPLACE THE CONTROL AT NO COST TO THE PURCHASER (OR OWNER) OTHER THAN TRANSPORTATION. MAGNETROL SHALL NOT BE LIABLE FOR MISAPPLICATION, LABOR CLAIMS, DIRECT OR CONSEQUENTIAL DAMAGE OR EXPENSE ARISING FROM THE INSTALLATION OR USE OF THE EQUIPMENT. THERE ARE NO OTHER WARRANTIES EXPRESSED OR IMPLIED, EXCEPT, SPECIAL WRITTEN WARRANTIES COVERING SOME MAGNETROL PRODUCTS.



BULLETIN N°: BE 46-150.0
EFFECTIVE: FEBRUARY 2016
SUPERSEDES: New

UNDER RESERVE OF MODIFICATIONS

BENELUX FRANCE	Heikensstraat 6, 9240 Zele, België - Belgique Tel. +32 (0)52.45.11.11 • Fax. +32 (0)52.45.09.93 • E-Mail: info@magnetrol.be
DEUTSCHLAND	Alte Ziegelei 2-4, D-51491 Overath Tel. +49 (0)2204 / 9536-0 • Fax. +49 (0)2204 / 9536-53 • E-Mail: vertrieb@magnetrol.de
INDIA	B-506, Sagar Tech Plaza, Saki Naka Junction, Andheri (E), Mumbai - 400072 Tel. +91 22 2850 7903 • Fax. +91 22 2850 7904 • E-Mail: info@magnetrolindia.com
ITALIA	Via Arese 12, I-20159 Milano Tel. +39 02 607.22.98 • Fax. +39 02 668.66.52 • E-Mail: mit.gen@magnetrol.it
RUSSIA	198095 Saint-Petersburg, Marshala Govorova street, house 35A, office 427 Tel. +7 812 320 70 87 • E-Mail: info@magnetrol.ru
U.A.E.	DAFZA Office 5EA 722 • PO Box 293671 • Dubai Tel. +971-4-6091735 • Fax +971-4-6091736 • E-Mail: info@magnetrol.ae
UNITED KINGDOM	Unit 1 Regent Business Centre, Jubilee Road Burgess Hill West Sussex RH 15 9TL Tel. +44 (0)1444 871313 • Fax +44 (0)1444 871317 • E-Mail: sales@magnetrol.co.uk

www.magnetrol.com

OUR NEAREST REPRESENTATIVE